

**ASAHI
PENTAX**

**TAKUMAR
INTERCHANGEABLE
LENSES**

OPERATING MANUAL

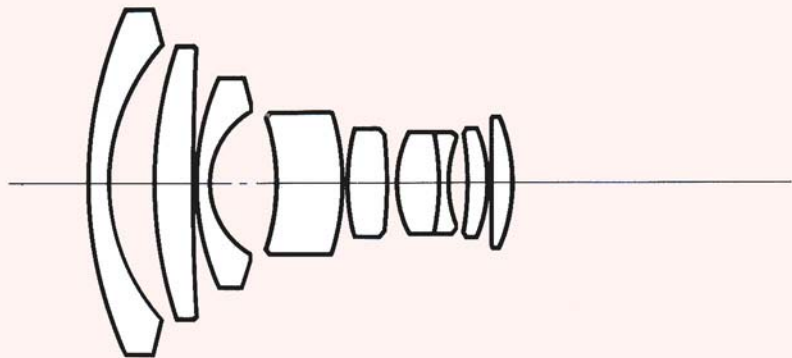



CONTENTS

Changing Lenses	3
How to Place a Removed Lens	4
Lens Care and Storage	5
Automatic Diaphragm	7
Preset Diaphragm	8
Click-stop Diaphragm	8
Square Hoods	9
Built-on Hoods	11
Holding a Telephoto Lens	12
Fixed Focus Mark	13
Infra-red Index	14
Tripod Mounting and Camera Position Adjustment	15
Exposure with Telephoto Lenses	17
Handling and Carrying Telephoto Lenses	18
Special Tripod for 1000mm and 500mm	19
Muzzle Sight and Back Sight	22
Zoom Lens	23
Macro-Takumar Lenses	25
Bellows-Takumar	27
Filters	28
Specifications	29

CHANGING LENSES

Takumar lenses feature extremely simple screw mounting. To change a lens, just unscrew it and then screw in the new one. Holding the new lens as shown in picture A will make initial threading easier. Be sure to hold the lens perpendicular to the camera body.

The lens can be screwed in as shown in picture B, but be sure to tighten it by holding the base as shown in picture C. When removing a lens, begin by turning the base.



HOW TO PLACE A REMOVED LENS

When your lens is removed from the camera, place it with its front side down as shown in the photo below, except for the 17mm fish-eye. To protect the rear lens element, put the rear lens cap on. Telephoto lenses with tripod mounts can safely be laid on their sides, for they will not roll.



LENS CARE AND STORAGE

Do not use or store a lens in an extremely damp location, especially one with salt spray. It is an excellent practice to protect the lens with a filter, not only at the seashore, but also anywhere dust or moisture is present. If the lens becomes dirty, do not wipe it with a

handkerchief, for it may scratch the surface. Instead, blow away the dirt with a rubber blower and soft brush, as shown in the picture.

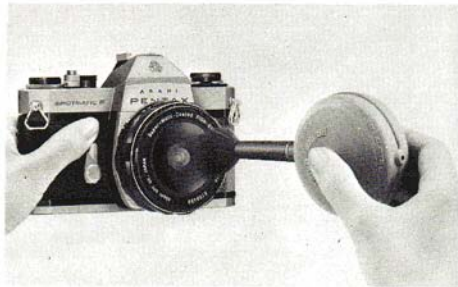

If you touch the lens surface by accident, or if it is too dirty to clean with the blower, use soft tissue paper or a very soft cloth, wrapped around a matchstick, etc. This can be dampened with lens cleaning solution or alcohol. Wipe in a spiral pattern, from the center out. For larger lenses, wrap the tissue or cloth around the tip of your finger instead of a matchstick. Be sure to shift the cloth or paper frequently, to avoid wiping with a dirty part. A few wipes over any stained part of the lens will be good enough. If the lens stains cannot be removed by these means, take the lens to an authorized service center for professional servicing.

Moisture and dust are not the only possible danger to a lens. Heat, shocks and scratches

can also be harmful. So be very careful not to bump or drop it, and never put it in its case without its protective caps. The wise practice is to put both the front and rear caps on the lens as soon as it is removed from the camera, and then to store it in its leather case. If the lens is not used for some time, especially during humid weather, it should be removed from its case at regular intervals and checked for fungus. If any dampness is present, thoroughly dry the case. Light fungus can easily be wiped off.

AUTOMATIC DIAPHRAGM

SMC Fish-Eye-Takumar	17 mm F4
SMC Takumar	20 mm F4.5
SMC Takumar	24 mm F3.5
SMC Takumar	28 mm F3.5
SMC Takumar	35 mm F2
SMC Takumar	35 mm F3.5
SMC Takumar	50 mm F1.4
SMC Takumar	55 mm F1.8
SMC Takumar	55 mm F2
SMC Takumar	85 mm F1.8
SMC Takumar	105 mm F2.8
SMC Takumar	120 mm F2.8
SMC Takumar	135 mm F2.5
SMC Takumar	135 mm F3.5
SMC Takumar	150 mm F4
SMC Takumar	200 mm F4
SMC Takumar	300 mm F4
SMC Takumar-Zoom	45-125 mm F4
SMC Takumar-Zoom	85-210 mm F4.5
SMC Macro-Takumar	50 mm F4
SMC Macro-Takumar	100 mm F4

SMC Takumar interchangeable lenses are completely automatic, just like standard lenses. In spite of variations in size, the distance scale and focusing ring on each lens works the same way.

When the preview lever is in automatic position (AUTO marked on the lens completely visible), the fully automatic diaphragm is at its largest aperture at all times, except for the instant of exposure. If you move the preview lever to manual position (MAN marked on the lens completely visible), this stops the diaphragm to the aperture selected and shows you exactly how much depth of field will appear in your picture. When the exposure meter switch of the Spotmatic is turned to the "on" position, the lens diaphragm changes from automatic to manual position even though the preview lever is in the "AUTO" (automatic) position. When using fully automatic SMC Takumar lenses on older camera models such as K, S2, H2, etc., the lens aperture cannot be set automatically, because these cameras have no fully automatic diaphragm mechanism. In this case, push the preview lever to MAN so that the lens can be operated manually.

PRESET DIAPHRAGM

SMC Bellows-Takumar 100mm F4

The above lenses all have preset diaphragm. As an example, the photo at the right shows the 200mm F5.6 diaphragm rings. It differs from the ordinary lens in that it has two rings. Ring ① is for presetting, while ② is for normal diaphragm adjustment. First set the ring ① at the desired aperture. Open the ring ② fully for focusing, and then turn it back so that it is lined up with the preset ring. This can be easily done because the ring hits a stop, so it is not necessary to watch your hand once you are sure the preset position is correct.

CLICK-STOP DIAPHRAGM

SMC Takumar 400mm F5.6
SMC Takumar 500mm F4.5
SMC Takumar 1000mm F8
SMC Takumar-Zoom 135-600mm F6.7

The click-stop diaphragm derives its name from the fact that as the diaphragm ring is turned, it clicks into place at each position of the indicated scale. This is also included in the large, super-telephoto lenses. It affords more efficient diaphragm ring movement when re-setting after opening the diaphragm for focusing.





SQUARE HOODS AND THEIR USE

SMC Takumar	20mm F4.5
SMC Takumar	24mm F3.5
SMC Takumar	28mm F3.5
SMC Takumar	35mm F2

This new compact square hood affords excellent versatility plus high efficiency. It has been specially designed for the above lenses. Match the white dot on the hood to that on the connecting ring and then tighten the ring only, as shown in the photos. Hold the hood with one hand and twist the ring approximately 2cm to the right to tighten.

When using the special hoods for the 35mm F2 and 20mm F4.5, screw them into the front frame of the lens. After tightening the hood, rotate it slightly to position it horizontally.

NOTE:

A difference of up to 5° between the hood angle and camera body is safe, but if the hood is twisted more than that, part of the picture will be blocked. With the 24mm and 28mm lenses, attach the hood to the front frame of the lens even when filters are used.

ROUND HOODS

SMC Takumar	35mm F3.5
SMC Takumar (A)	50mm F1.4
SMC Takumar (A)	55mm F1.8
SMC Takumar	85mm F1.8
SMC Takumar (B)	105mm F2.8
SMC Takumar (B)	120mm F2.8
SMC Takumar (C)	135mm F2.5
SMC Takumar (D)	135mm F3.5

SMC Takumar (D)	150mm F4
SMC Takumar (C)	200mm F4
SMC Takumar Zoom	45-125mm F4
SMC Takumar Zoom	85-210mm F4.5
SMC Bellows-Takumar (B)	100mm F4
SMC Macro-Takumar (B)	100mm F4

The hood pictured at the right is the most widely used for Takumar lenses. It attaches to the front of the lens, but when not in use it can be conveniently stored by reversing it over the front of the lens to reduce the overall length.

The letters (A) (B) (C) (D) in the above list indicate that there are four groups of lenses, the lenshood for which can be used in common respectively. Even if the thread diameters are exactly the same, do not use the hood on the other lens unless it has the same indicating letter. The hood can be used with a lens which has a focal length longer than that indicated on the hood, but in this case its effect will be reduced. On the other hand, a

hood should never be used with a lens of shorter focal length than that indicated, because this will result in part of the picture being blocked.



BUILT-ON HOODS

SMC Takumar	300mm F4
SMC Takumar	400mm F5.6
SMC Takumar	500mm F4.5
SMC Takumar	1000mm F8
SMC Takumar-Zoom	135-600mm F6.7



Since a super-telephoto lens has an extremely narrow angle of view, the diameter of the hood can be about the same as that of the lens. The hood, therefore, is fixed onto the lens body.

Takumar lenses listed at the left have built-on lenshoods. They thus have an added advantage of providing a hood whenever needed: simply extend it as shown in the photo. When it's not needed, just slide it back. Because of the built-in slip protector, the hood should be returned at the beginning, after which it will slide back smoothly.

HOLDING A TELEPHOTO LENS

Out-of-focus photos are mostly due to camera movement when the shutter is released. When using a telephoto lens, pay careful attention to holding the camera, because of the greater length, larger size and weight, and the fact that the center of balance is farther forward. The best way to assure a steady camera position is to use a tripod.

When using a telephoto lens, the best posture is that shown in the photo: left hand extended and supporting both lens and camera body, with its thumb and index finger used to rotate the focusing ring. Both elbows should be pressed close to the body, with the upper arms hugging the ribs. Although 200mm and larger super-telephoto lenses are usually used with a tripod, if one is to be hand-held, aim it as you would a gun. Assume a stable posture with the lens aimed slightly to the left.

When the camera body is turned sideways, there is a special danger of jiggling at the time of shooting. In this case, hold the camera as shown in the second photo, with the left hand supporting the lens and operating the focusing ring and the rear of the camera pressed against the forehead.

Although these positions require experience to attain, with practice you should be able to use up to a 400mm lens and obtain clear pictures without a tripod.

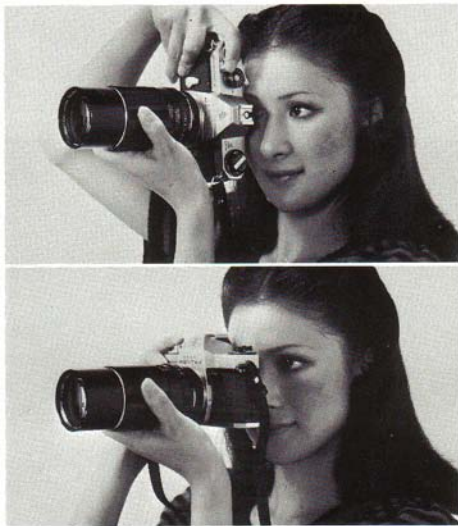

FIXED FOCUS MARK

SMC Fish-Eye Takumar	17mm F4
SMC Takumar	20mm F4.5
SMC Takumar	24mm F3.5
SMC Takumar	28mm F3.5
SMC Takumar	35mm F2
SMC Takumar	35mm F3.5

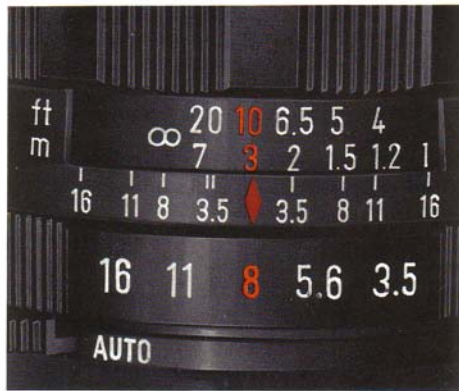

Since the fish-eye and wide-angle lenses have a great depth of field, they are suited for snapshots. To obtain the maximum depth of field, convenient marks have been included on the Takumar wide-angle lenses. They are shown in red figures on the diaphragm and distance scales. If you set these figures to the index, you do not have to turn the focusing ring every time you want to take a snapshot. The photo at the left indicates that the lens diaphragm is set at F8 and the distance scale at 3 meters, both figures being the fixed focus marks. Read the depth-of-field guide, and you will see that this setting affords a depth of field from 1.5 meters to infinity; within this field everything will be in focus.

However, even without using the fixed focus mark, it is possible to make extremely efficient judgments about the depth of field by checking it on the scale which shows the relation between the distance setting and aperture.

INFRA-RED INDEX

When taking infra-red photographs, the focal point shifts slightly, and therefore, the lens must be extended accordingly. The difference varies depending on the lens, and it is indicated by the small "R" index or short orange line. In infra-red photography, use this infra-red index. First, focus your lens on your subject. Determine the lens-to-subject distance from the distance scale. Then match your lens-to-subject distance to the "R" mark by turning the distance scale accordingly. Like the photo below, if your subject is in focus at infinity, turn the distance ring and move the infinity (∞) mark to the "R" index. Also, remember to use an R2 or O2 filter and special infra-red film in this special photography.

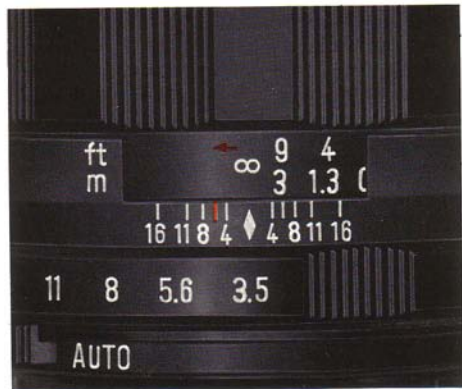

TRIPOD MOUNTING AND CAMERA POSITION ADJUSTMENT

SMC Takumar	300 mm F4
SMC Takumar	400 mm F5.6
SMC Takumar	500 mm F4.5
SMC Takumar	1000 mm F8
SMC Takumar-Zoom	135-600 mm F6.7

The lenses listed at left have a tripod seat ring at the proper position on their barrels. The reason is that if the tripod is attached to the camera body, instead of to the lens, the extra size and weight of the lens will cause imbalance to the whole unit. By simply loosening the fastening knob on the tripod seat ring as shown in the photo A, you can easily turn the camera and lens vertically or horizontally.

Since the 500mm and 1000mm lenses are extremely heavy, an even easier method has been devised. The camera body can be turned 90° to the left, where it will click into place, by first loosening the second ring (from the



camera body) of the lens barrel as shown in photo B.

The tripod seat ring on the 1000mm lens is larger and sturdier than the others, and it affords easy bayonet-type tripod mounting. When shooting with the 300mm lens without using a tripod, remove the tripod seat ring to dispense with its unnecessary weight.

Then loosen the fastening knob and turn the tripod seat ring 180° until the tripod screw hole is lined up with the depth-of-field scale as shown in photo D. Then the ring can easily be slipped off the lens.

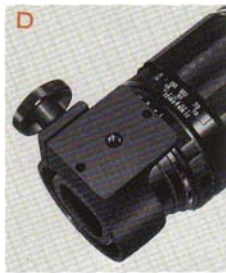

Even if the tripod is used, a slight shock to the camera or a super-telephoto lens used may cause a blurred picture, especially when a slow shutter speed between 1/60 and 1/4 is used. So, be sure to use a cable release in such a case and never touch the camera carelessly. Also, when shooting with the 300mm or zoom lens at such slow shutter speeds, it is better to mount the camera body, rather than the seat ring on the lens, on the tripod, as you can thus minimize the vibration.



EXPOSURE WITH TELEPHOTO LENSES

Lenses of extremely long focal length (over 200mm), when used for long distance photography, have a tendency to overexpose, due to gas, moisture, dust and other impediments in the air.

To obtain sharp images, at least a UV filter should be used; in the case of black-and-white film, the use of a Y2 or R2 filter is recommended. In color photography, exposures should be somewhat on the lower side to bring out true richness of the colors.

The type of film, must of course be selected to match the object, but generally soft gradation film should be avoided. Care must also be taken in the exposure measurement and developing to counteract the danger of flat negatives with poor contrast.

HANDLING AND CARRYING TELEPHOTO LENSES



With an extremely long lens attached, the camera becomes a bit unwieldy. When carrying it without the lens cap, point the lens downward as shown in the photo. Be especially careful not to bump the lens against



objects when moving in a narrow or crowded area. Try to carry the camera in such a way that it will be immediately ready for snapping the next shot.

SPECIAL TRIPOD FOR 1000mm AND 500mm LENSES

SMC Takumar
SMC Takumar

500mm F4.5
1000mm F8

Take the tripod out of its case, remove the belt and spread the legs. The length of the legs can be adjusted by loosening the fastening screws as shown in the photo. Pull them out to the desired length and retighten the screws. The spread angle of the legs can be restricted by hooking the chain from one leg to the

other. Remove the panning lever from below the head assembly by turning it counter-clockwise, and screw it into one of the two holes provided on the side of the head. This lever moves the head and can be turned clockwise to lock it in position.

The adapter (third photo from left) attached to the panning head is used for the 500mm lens only. Remove it when using the tripod for the 1000mm lens.

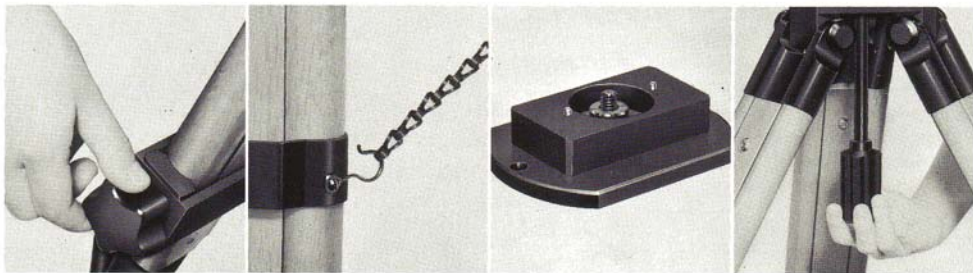

Adjust the head so that it is level and turn the bayonet ring so that the white dot on its edge is lined up with the two silver protrusions on the top of the inner surface. Then set the lens on the tripod so that the holes in its base slip onto these two protrusions. Finally, turn the bayonet ring clockwise to secure the lens. Note that if the lens mounting base does not slip onto these two protrusions, the lens is not securely in place. Make certain that the base holes are engaged with the silver protrusions.



To aim the camera, loosen the panning lever so that it can be moved, then tighten it once the camera is aimed. When shooting a moving object, do not tighten the lever, but hold the camera with your right hand. Operate the focusing knob with your left hand and follow the object. Be careful not to remove your hands from the camera, for it may swing out of place. Also use as fast a shutter speed as possible.



Focusing can be done by turning the knob at the bottom of the lens as shown in the photo A.

When setting the tripod on soft ground, stabilize it by anchoring the foot pegs in the ground. To protect floors, use the peg cups. Attach them with their plastic straps as shown in the photo C. On slippery floors, attach the rubber caps over the cups (photo D).



MUZZLE SIGHT AND BACK SIGHT

SMC Takumar	500mm F4.5
SMC Takumar	1000mm F8

Because of the narrow field of vision with extremely long focal length lenses, aiming should be done with care.

These lenses are therefore equipped with sights which make it easier to locate the object than through the viewfinder alone. Use these sights for roughly aiming the lens. Then complete precision aiming through the viewfinder.

When shooting very fast-moving objects, use only the sights.

The sights on the 1000mm lens can be folded down.

Other Points

When storing the 500mm lens in its case, rotate the tripod mounting base 180° to bring it next to the sights. This will prevent the sights from rubbing against the case.

The 1000mm lens case is of sturdy metal construction; it can hold the lens with the camera body attached.



ZOOM LENS

SMC Takumar-Zoom	45-125mm F4
SMC Takumar-Zoom	85-210mm F4.5
SMC Takumar-Zoom	135-600mm F6.7

The Takumar zoom lens features the same automatic diaphragm found in all Super-Takumar lenses. The focus can be adjusted simultaneously with the zooming action. Just turn the zoom-focus ring to focus, and at the same time slide it back or forward to zoom. This is possible because the focus and zooming are independent—an exclusive feature which permits fast-action shooting even while zooming.

The calibration on the lens barrel shows the focal length for any zooming position, (but this need not be consulted because optimum picture composition and area can be easily determined through the viewfinder). When you want to shoot at a closer range than the zoom lens focusing will permit, attach the supplied attachment lens (stored inside the lid of the case). Focusing is now possible within the range indicated by the white calibration (in meters).

Once focused, the Takumar zoom lens maintains the focus setting even while zooming. It is a good practice to focus at maximum focal length, i.e., with the largest possible image, and then zoom back to the desired field of view. This ensures maximum focus accuracy.



CAUTION:

The 45-125mm Zoom is designed for open-aperture metering, but the 85-210mm and 135-600mm Zoom lenses are designed for stop-down metering; therefore, when using these lenses on the ES, ES II and Spotmatic F, push up the stop-down lever of the camera for stopped-down aperture reading.



MACRO-TAKUMAR LENSES

SMC Macro-Takumar	50mm F4
SMC Macro-Takumar	100mm F4

The SMC Macro-Takumar lens is especially designed for utmost performance in close-up and macrophotography. Its focusing accuracy in close-up photography defies comparison with conventional lenses and assures sharp resolution even with the diaphragm wide open. So it is also effective as an enlarging lens, using a Leica-mount adapter B.

The magnification range is from 1/2 to infinity. So it can be used also for distant photography. The front lens element of the 50mm f/4 is so greatly retracted it eliminates the need for a lenshood. Its almost completely distortion-free design makes this lens especially suited for reproduction of art work.

Magnification
(figure is denominator)



Magnification

After focusing, look at the magnification scale. If the figure 2 is close to the white line as shown in the photo, you will photograph at the magnification of 1/2. When using an unintegrated exposure meter, you should give more exposure than indicated by the meter, according to the exposure factor table on the bottom right. (When using a Pentax with built-in through-the-lens light meter, disregard the exposure factors.)

As a general rule in close-up photography, the aperture should be set first and stopped down as far as possible because of the extremely shallow depth of field at such close ranges. Since the shutter speed has no intermediate setting, close down the diaphragm by half a stop when the magnification is 1.5. When the magnification is 2, slow down the shutter speed or open up the diaphragm by one stop respectively.

Exposure Factor Principles

The amount of light reaching the film is in inverse proportion to the square of the distance from the lens to the film plane. As the lens is a considerable distance away from this plane in close-up and macrophotography, the resulting drop in the amount of light reaching the film must be compensated for.

Since the through-the-lens exposure meter of the Pentax measures the exact amount of light reaching the film plane, these considerations are not necessary. This is another great advantage of the through-the-lens exposure system.

Exposure Factors for SMC Macro-Takumar

(when used on a camera with no TTL metering system)

Magnification	$\infty \sim 1/10$	1/8~1/4	1/3.5~1/2
Exposure Factor	X 1	X 1.5	X 2

SMC BELLOWS-TAKUMAR

The Bellows-Takumar has no focusing ring, and is used only with the Bellows Unit or the Auto-Bellows. This short-barrel lens allows focusing from life-size close-ups, with the bellows extended to its maximum length, up to infinity, with the bellows folded to its shortest length. Close-ups can be taken from a distance because of its focal length of 100mm. It is

equipped with a convenient preset diaphragm, accepts 49mm-size standard filters and lens-hood, and is extremely light in weight for fast handling for nature-life and other scientific photography.

When using this lens, also refer to the operating manual for the Bellows Unit or the Auto-Bellows.



FILTERS

The filters for all wide-angle, standard and telephoto lenses up to 400mm are attached by screwing them into the front end of the lens. The 17mm Fish-Eye has UV, Y2 and O2 filters built in. They are brought into play by turning the front ring. For other filters, use gelatin types. Remove the ring from the back of the lens by turning it counter-clockwise. Cut gelatin filter into a circle and insert this under the spring on the ring, as shown in the photo. If the gelatin filter is not correctly attached, it may fall into the camera body.

The 500mm and 1000mm lenses have threads on the back which accept 49mm screw-in type filters.

As illustrated below, hold the seat ring at the back of the lens. Loosen the seat ring retainer ring by turning it to the left. The seat ring will then come off. Screw the filter into the front end of the removed seat ring. When mounting the lens to the camera body, it is convenient to first attach the removed seat ring to the camera body. As both the 500mm and 1000mm lenses have exactly the same seat ring, they can easily be interchanged.



SPECIFICATIONS

Name of Lenses	Focal Length & Maximum Aperture	Minimum Aperture	Lens Element	Diaphragm	m.	ft.	Minimum Focusing Distance	Angle of View (degrees)	gr.	ozs.	mm	mm	mm	Filter Size	Lenshood Size	Lens Cap Size
SMC Fish-Eye Takumar	17mm f/4	22	11	FA	0.2	0.66	180 ^①	228	7.98	BI	—				60	
SMC Takumar	20mm f/4.5	16	11	FA	0.2	0.65	94	251	8.79	77	58 *				60	
SMC Takumar	24mm f/3.5	16	9	FA	0.25	0.8	84	247	8.71	58	60 *				60	
SMC Takumar	28mm f/3.5	16	7	FA	0.4	1.3	75	218	7.6	49	51 :				51	
SMC Takumar	35mm f/2	16	8	FA	0.4	1.25	62	242	8.53	49	49 :				51	
SMC Takumar	35mm f/3.5	16	5	FA	0.45	1.5	62	152	5.4	49	49				51	
SMC Takumar	50mm f/1.4	16	7	FA	0.45	1.5	46	252	8.8	49	49				51	
SMC Takumar	55mm f/1.8	16	6	FA	0.45	1.5	43	201	7.0	49	49				51	
SMC Takumar	55mm f/2	16	6	FA	0.45	1.5	43	201	7.0	49	49				51	
SMC Takumar	85mm f/1.8	16	6	FA	0.85	2.75	29	341	11.9	58	58				60	
SMC Takumar	105mm f/2.8	22	5	FA	1.2	4	23	290	10.2	49	49 *				51	
SMC Takumar	120mm f/2.8	22	5	FA	1.2	4	20	340	11.9	49	49 *				51	
SMC Takumar	135mm f/2.5	22	6	FA	1.5	5	18	470	16.5	58	58 *				60	
SMC Takumar	135mm f/3.5	22	4	FA	1.5	5	18	343	12.1	49	49 *				51	

All these lenses fit any Pentax model which has a 42mm threaded lens mount.

BI=3 filters built-in. M=Manual. FA=Fully Automatic. PS=Preset. SMC=Super-Multi-Coated. UA=Ultra-Achromatic. ①=Diagonal coverage. ②=Supplied with wooden tripod and carrying cases. All lenses, including

Name of Lenses	Focal Length & Maximum Aperture	Minimum Aperture	Lens Element	Diaphragm	m.	ft.	Minimum Focusing Distance	Angle of View (degrees)	gr.	ozs.	mm	mm	mm	Filter Size	Lenshood Size	Lens Cap Size
SMC Takumar	150 mm f/4	22	5	FA	1.8	6	16.5	324	11.3	49	49 •	51				
SMC Takumar	200 mm f/4	22	5	FA	2.5	8.2	12.5	550	19.3	58	58 •	60				
SMC Takumar	300 mm f/4	22	5	FA	5.5	18	8	946	33.1	77	•	85				
SMC Takumar	400 mm f/5.6	45	5	M	8	27	6	1300	45	77	•	85				
SMC Takumar	500 mm f/4.5	45	4	M	10	32.8	5	3500	122.5	49	•	127				
SMC Takumar	1000 mm f/8 ^②	45	5	M	30	98	2.5	5500	192.5	49	•	143				
SMC Takumar-Zoom	45-125 mm f/4	22	14	FA	1.5	6	51~20	605	21.2	58	58	60				
SMC Takumar-Zoom	85-210 mm f/4.5	22	11	FA	3.5	12	29~11	705	24.9	58	58	60				
SMC Takumar-Zoom	135-600 mm f/6.7	45	15	M	6	20	18~4	4060	142.1	49	49	51				
SMC Macro-Takumar	50 mm f/4	22	4	FA	0.234	0.77	46	248	8.74	49	—	51				
SMC Macro-Takumar	100 mm f/4	22	5	FA	0.45	1.5	24.5	350	12.3	49	—	51				
SMC Bellows-Takumar	100 mm f/4	22	5	PS	—	—	24	139	4.9	49	49 •	51				
Ultra-Achromatic-Takumar	85 mm f/4.5	22	5	FA	0.6	2	29	248	8.7	49	49	60				
Ultra-Achromatic-Takumar	300 mm f/5.6	22	5	FA	4.85	16	8	825	29.1	58	•	68				

standard lenses purchased separately, are supplied with leather case, straps, front and rear caps. All filters and lenshoods are screw-in type unless otherwise indicated.

(*Lenshood supplied with lens. • Clip on type)



Asahi Optical Co., Ltd. C.P.O. 895, Tokyo 100-91, JAPAN

Asahi Optical Europe N.V. Weiveldlaan 3-5, 1930 Zaventem Zuid-7, BELGIUM

Pentax Handelsgesellschaft mbH. 2000 Hamburg 54 (Lokstedt), Grandweg 64, WEST GERMANY

Pentax Corporation 9 Inverness Drive East, Englewood, Colorado 80112, U.S.A.

Pentax of Canada Ltd. 1760 West 3rd Avenue, Vancouver, B.C. V6J 1K5, CANADA

Asahi Optical Brasileira Ind. e Com. Ltda. Rua Estados Unidos, 1053, São Paulo-SP, BRASIL